

USER MANUAL

12V

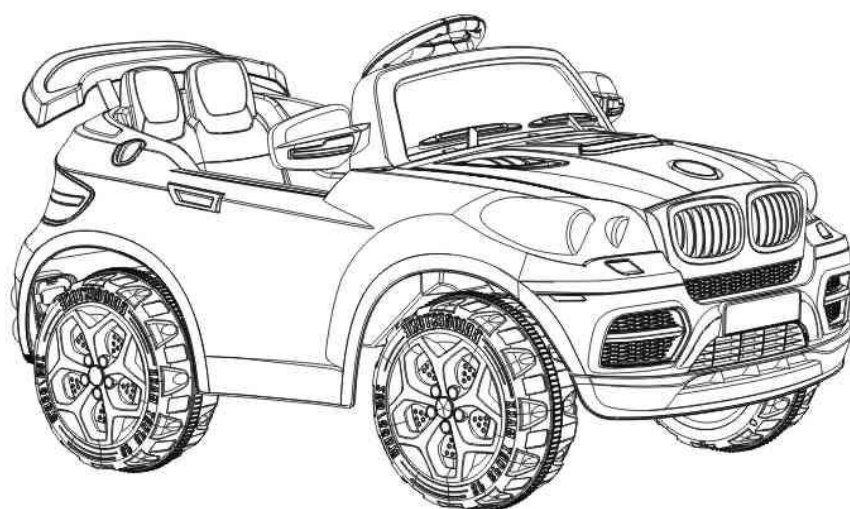

- Suitable for 3 years+.
 - Adult assembly required.
 - Tools needed for Assembly: Pliers (not included)
Phillips Screwdriver (not included)
-
- Please read this manual and save it with your original sales receipt.

1 Brief introduction and models -----	1
2 Important Safety Instructions -----	2
3 Parts List -----	4
4 Parts Diagram -----	5
5 Assembly Steps -----	6
6 How To Operation Your Vehicle -----	10
7 Charging The Vehicle -----	11
8 Caring For Your Vehicle -----	11
9 Problems And Solutions Guide -----	12
10 Disposal Of Battery -----	13
11 Remote operation explanation -----	14

Brief Introduction And Models

Thank you for choosing our vehicle. Each vehicle pattern is designed upon a unique mold : such as the realistically imitated vehicle and cute series . which bring different fun and feeling for your children.

We wish our vehicle to accompany your children for a happy childhood and your family will be filled with joy and happiness.

Suitable Age:	3+ Years	Load Capacity:	Under 40Kgs
Speed :	4.5Km/H	Size Of Car:	126*69*60 cm
Battery:	6V 7AH *2	Fuse:	15 A
Power Way:	Charging Type	Charge Time:	8-12 Hours
Charger :	Input: depend on local voltage Output: DC12V1000mA	Average Battery Life :	Approximately 300 times

Read carefully and follow all the instructions

⚠ WARNING ! CAUTION

Assembly/Used

- ⚠ New vehicle requires adult assembly. Children can be harmed by small parts, sharp edges and sharp points in the vehicle's unassembled state. Care should be taken in unpacking and assembly of the vehicle. Children should not handle parts, or help in assembly of the vehicle.
- ⚠ Choking Hazard — Small Parts. Not for children under 3 yrs.
- ⚠ Always properly handled the protective material and poly bags before assembly. forbidden to children's play and have suffocation danger!
- ⚠ Suitable for age 3+years; Maximum user weight is 40Kgs.
- ⚠ **Direct Adult Supervision Required.** Never Leave Child unattended. Always keep child in view when child is in vehicle. Teach appropriate safety rules to your child before allowing operation of this vehicle . these rules should also be reviewed with other playmates who want to drive this vehicle . Make sure children know and follow these rules for safe driving and riding:
 - Always wear shoes;
 - Always sit on the seat;
 - Always wear a helmet when riding;
 - Only one rider at a time;
- ⚠ Keep Children within Safe Riding Areas, these areas must be:
 - Away from steps/cars/driveways/roads and alleys;
 - Away from sloped/inclined surfaces/swimming pools or other bodies of water;
 - Away from other dangerous places;
 - ONLY outdoors .Generally flat ground/playground/Garden asphalt and other hard surfaces;
- ! Never use in the dark. A child could encounter unexpected obstacles and have an accident. Operate the vehicle only in the daytime or a well-lit area . To avoid damaging the motors and gears, stop the vehicle before shifting from forward to backward switch .
- ⚠ Please turn forward/stop/backward switch to "O" in the state of no-driving. turn off power switch.(notice:this switch only control the parts of drive.)
- ! This vehicle has adjustable play seat belts. please instruct children how to tie the safety belt before using ,guarantee the security.
- ! Do not let any child touch the wheels or be near them when the car is moving .
- ! Do not tow anything behind the vehicle or overload it. Do not exceed the maximum weight capacity of 40 kg.











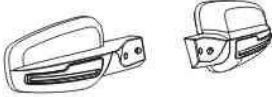

Battery/Charger / Alkaline Batteries

- ⚠ Battery charging must be done by adults only.
- ⚠ The battery /charger /alkaline batteries are not toy, strictly children play.
- ⚠ Non-rechargeable batteries are not to be recharged. Do not charge Non-rechargeable batteries.
- ⚠ Remove rechargeable batteries from the vehicle before charging.
- ⚠ Do not mix old and new batteries or batteries of different types: alkaline, standard (carbon-zinc) or rechargeable (nickel-cadmium).
- ⚠ Insert batteries as correct polarity inside the battery compartment.
- ⚠ Remove batteries during long periods of non-use.
- ⚠ Always remove exhausted batteries from the product.
- ⚠ Never short-circuit the battery terminals.
- ⚠ Use only with manufacturers prescribed rechargeable battery and charger (both included) . ;
- ⚠ **DO NOT** use the battery or charger for any other product. Could cause overheating, fire or explosion.
- ⚠ **DO NOT** open the battery and the charger .
- ⚠ **DO NOT** charge battery upside down.
- ⚠ Always maintain battery dry. Don't let the contact fresh water or salt water.

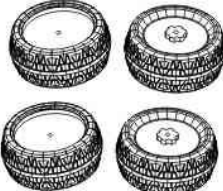
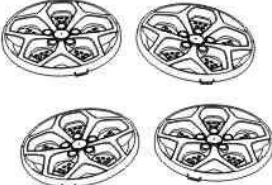
Charge

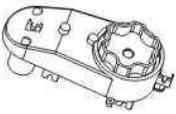
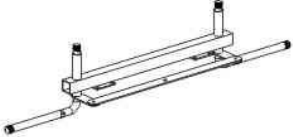
- ⚠ **ONLY** adults may handle or charge the battery. Never allow child to handle or charge the battery. Turn off power switch before charge the battery.
- ! When the vehicle's normal speed apparent slow down or after each use, recharge the battery for 8~15 hours, never charge the battery longer than 18 hours .charge the battery after each use, regardless of how long the vehicle was used.
- ! Examine the battery, charger and their connectors for excessive wear or damage each time you charge the battery. if damage or excessive wear is detected, do not use the charge or the battery until you have replaced the worn or damaged parts.
- ! Charge the battery at least once per month, even if the vehicle has not been used.
- ! It's normal that charger and battery are tepid while charging.
- ! Charge the battery in a dry area **ONLY**.
- ! In room temperature below 5 degrees centigrade, charging the actual to lengthen 3 ~ 5 hours. Below - 5 Celsius please do not use this product.

- Please identify all parts before assembly and save all packaging material until assembly is complete to ensure that no parts are discarded.

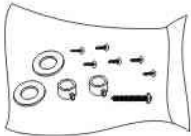
		
<p>1 Vehicle Body</p>	<p>2 Dashboard Assembly</p>	<p>3 Viewfinder</p>
		
<p>4 Steering Wheel</p>	<p>5 Seat</p>	<p>6 Spoiler</p>
		
<p>7 Wheel -4</p>	<p>8 Hubcap-4</p>	<p>9 Driving Connection-2</p>
		
<p>10 Gear Case-2</p>	<p>11 Front Axle</p>	<p>12 Rear Axle</p>
		
<p>13 Charger</p>	<p>14 Remote controller</p>	<p>15 Assembly package</p>

Parts Diagram

Note: Some Parts Shown are assembled on both sides of vehicle.

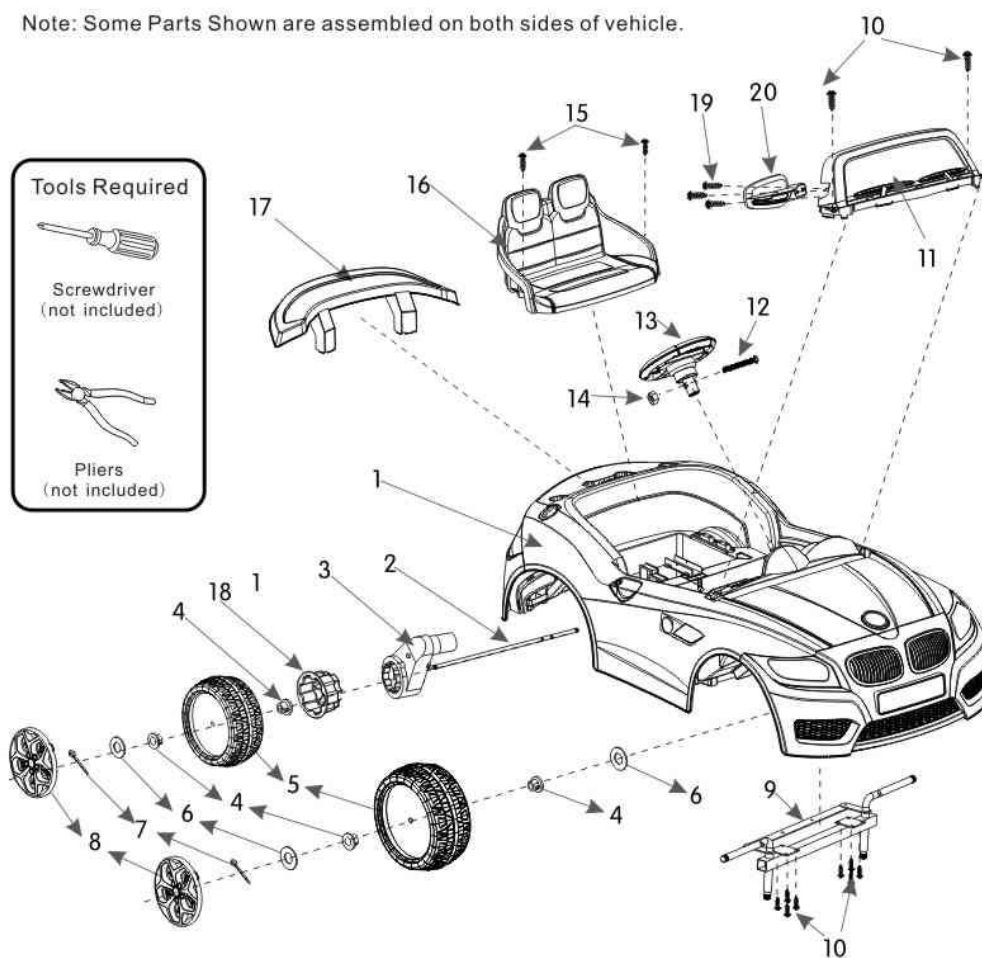

1	Vehicle Body	11	Dashboard Assembly
2	Rear Axle	12	M5*35 machine screw
3	Gear Case	13	Steering Wheel
4	∅ 12 Bushing	14	M5 Machine nut
5	Wheel-4	15	M4*12 Flat Head Screw
6	∅ 12 washer	16	Seat
7	Split Pin	17	Spoiler
8	Hubcap-4	18	Driving Connection
9	Front Axle	19	M4*10 Flat Head Screw
10	M4*12 Screw	20	Viewfinder

Note:

- 1 When in assembling any wheel to the axles, We provide three $\varnothing 12$ Washers. Please decide whether to increase washers to adjust tightness degree of the wheels free to turn. Ensure wheels!
- 2 Loosen the two screws in the seat cover position of vehicle body. Unplug the wire connector from the gear box connector, take out it.

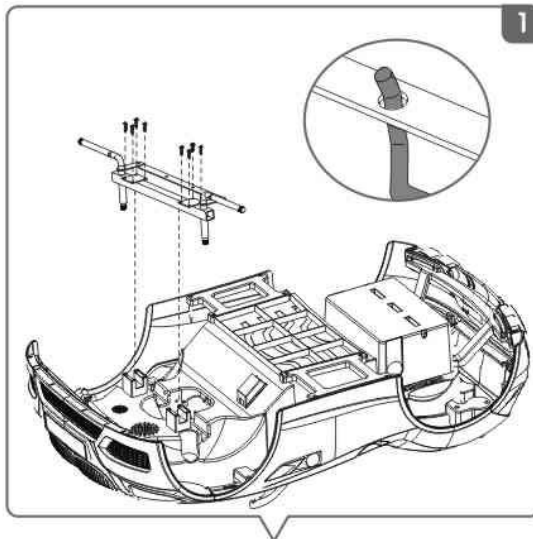

1

Front Axle Assembly

- Turn the vehicle body over.
- Fit the front axle into the vehicle body, insert with just eight screws into it and tighten.
- (make sure the stick shift fit into the hole in front axle .)

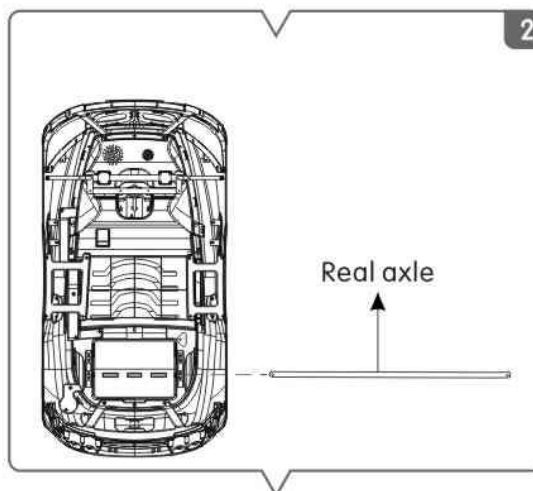

2

Real Axle Assembly

With pliers under the split pin from real axle, take down washers, bushings. Insert the real axle through the hole in the vehicle body.

3 Drive connection assembly

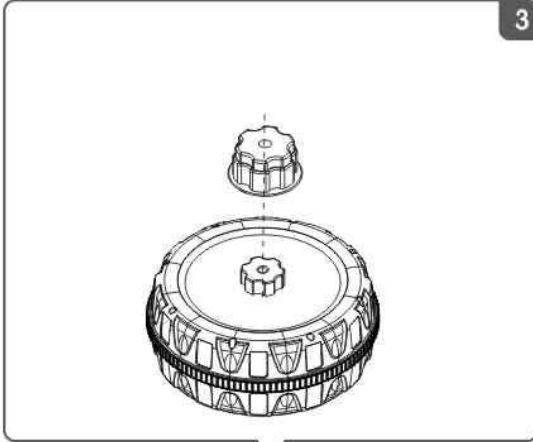

- Choose any two wheel wantonly for drive wheel.
- Fit the driving connection to the wheel position .

4 Driving Wheel Assembly

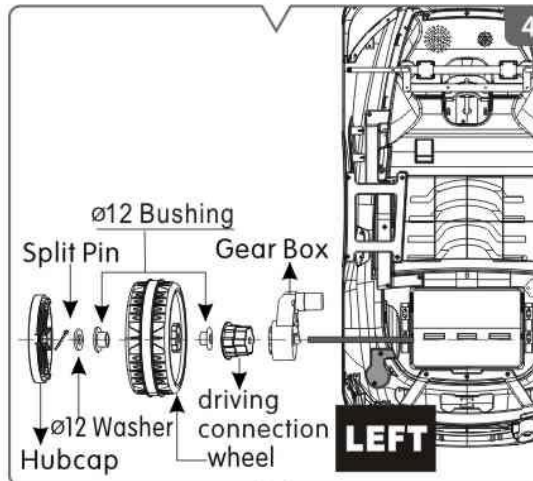

- According to the right Figure shows will components sequentially into. **(make sure the bushing fits into the hole in each side of a wheel.)**
- Secure it with split pin, then fixation on wheel cover.

5 Wheel Assembly

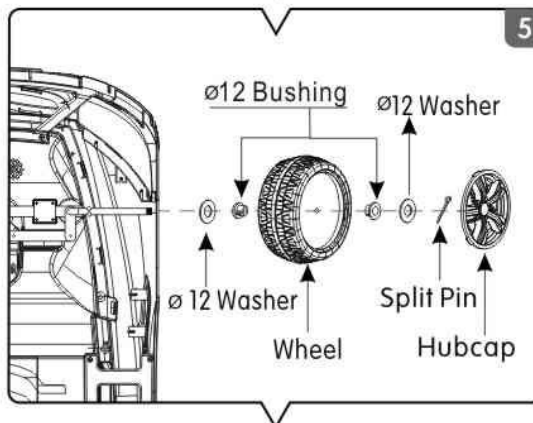

- With pliers under the split pin, take down washers, bushings.
- According to the right Figure shows will components sequentially into. **(make sure the bushing fits into the hole in each side of a wheel.)**
- Secure it with split pin, then fixation on wheel cover.

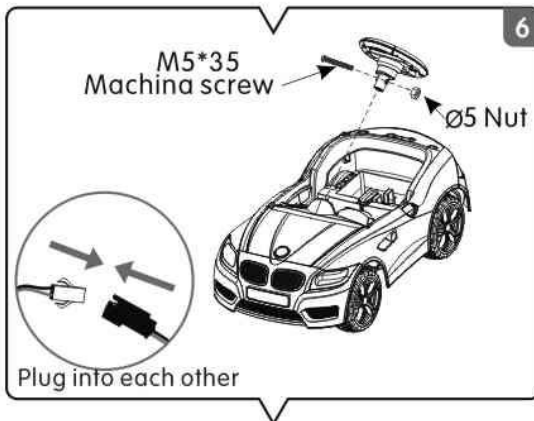

6 Steering wheel assembly

- Remove the M5x35 machine screw with a screwdriver.
- Plug the music connector into power connector.
- Insert the steering wheel onto end of the steering shaft, line up the holes in the steering wheel and the holes in steering shaft, insert the M5x35 machine screw and Ø5 nut back in the same location and tighten it with a screwdriver.

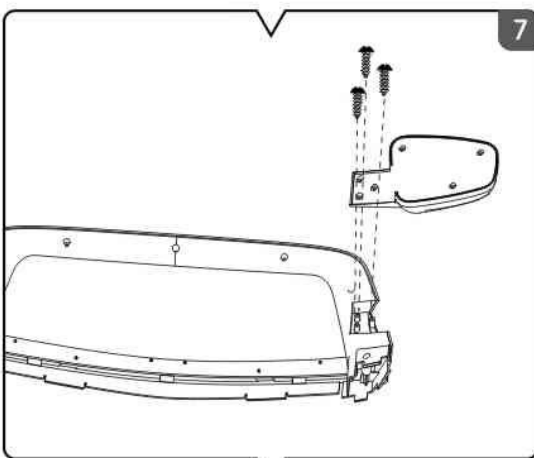

7 Viewfinder assembly

- Fit the viewfinder into the dashboard assembly relevant position.
- Insert With six M4*10 screws into the left viewfinder and tighten.

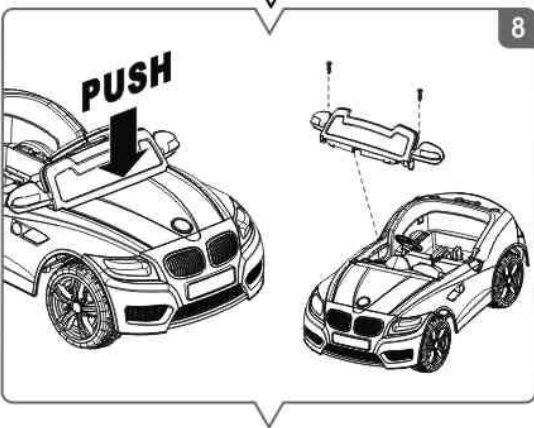

8 Windscreen assembly

- Fit the tab on each side of the windscreen into the slots in the vehicle body.
- Push each tab in until the windscreen "snaps" into place.

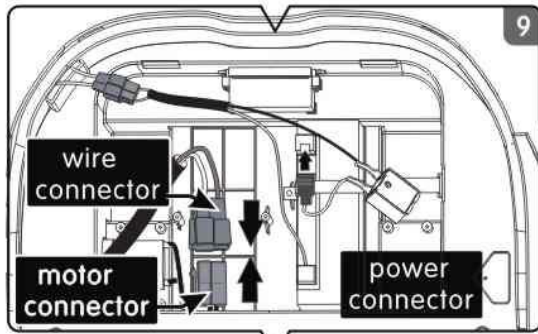

9

Connect the power supply

- Plug the wire connector into the motor connector.
- Plug the power connector into the terminal on battery as shown.

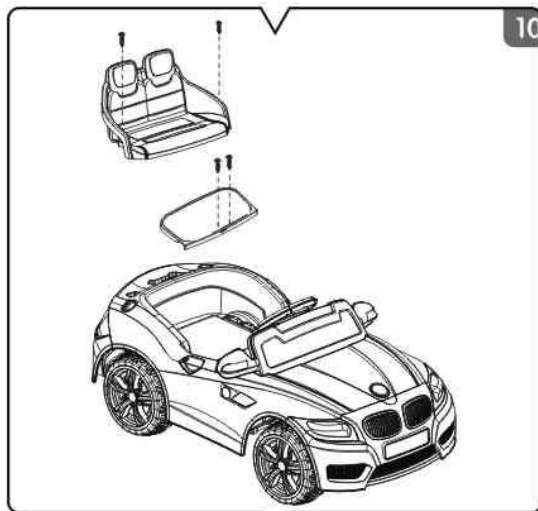

10

seat assembly

- fit the seat cover into the vehicle body, insert with just two screws into it and tighten.
- Insert the two tabs on the seat into the slots on the vehicle body. Secure it with M4x12 screw-2 with a screwdriver.

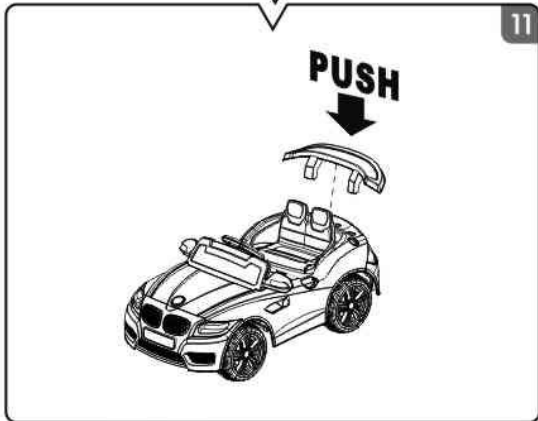

11

Spoilers assembly

- Fit the tab on each side of the spoilers into the slots in the vehicle body.
- Push each tab in until the spoilers "snaps" into place.

⚠ when changing the tap position, please make sure the vehicle has completely stopped, otherwise it will damage the gear box and motor.

! Check all screws, cap nuts and their protective coverings regularly and tighten as required. Check plastic parts on a regular basis for cracks or broken pieces. If damage or excessive wear is detected, do not use the charge or the battery until you have replaced the worn or damaged parts.

- If you want to use the remote control operation. Please refer to the remote control operation instructions page(page14) .

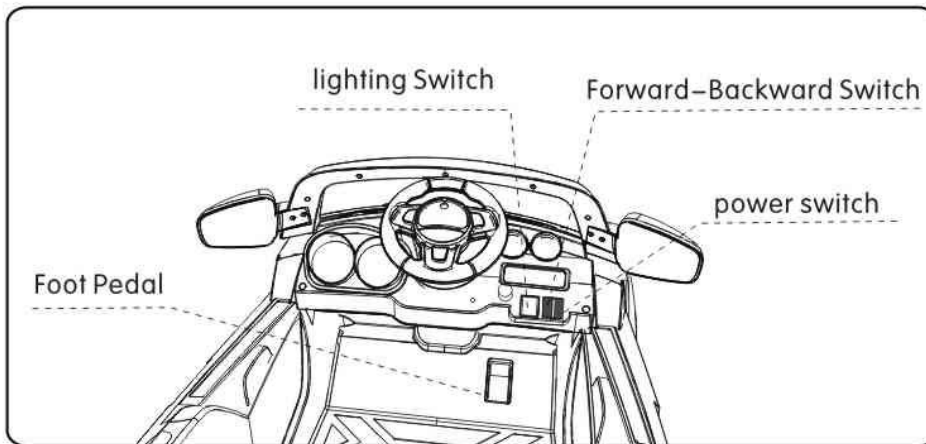

- POWER
Press the power switch when heard a voice "drops" after the car into the working status.
- FORWARD
1. Press the "Forward-backward switch" on the "Forward" position.
2. Press the "Foot pedal", the vehicle drives forward.
- STOP
The vehicle will brake automatically, when your child's foot is lifted from the "Foot pedal".
- BACK UP
1. Press the "Forward-Backward Switch" on the "Backward" position.
2. Press the "Foot Pedal", the vehicle will back up.
- lighting Switch
Press the "lighting Switch" on the "on" position ,with lighting.

How To Operation Your Vehicle

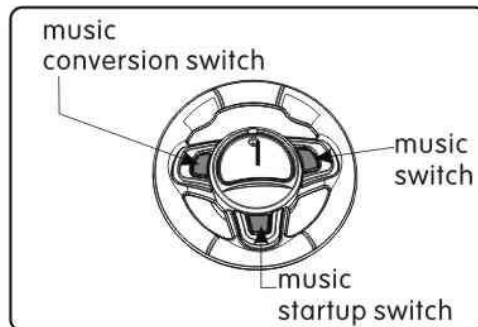

SOUNDS BUTTON



**Do not close to the ear ,
improper use can cause
hearing damage.**

- Click "music startup switch",
- First click "music switch" start playing music, headlights flashing.
- Press the "music conversion switch" Switching songs.
The second point press "music switch,"
Stop music playback;

- The third point press "music switch," Press the "music startup switch" switch for the horn;
- The fourth point press "music n button" for "music switch "to switch.

Charging The Vehicle

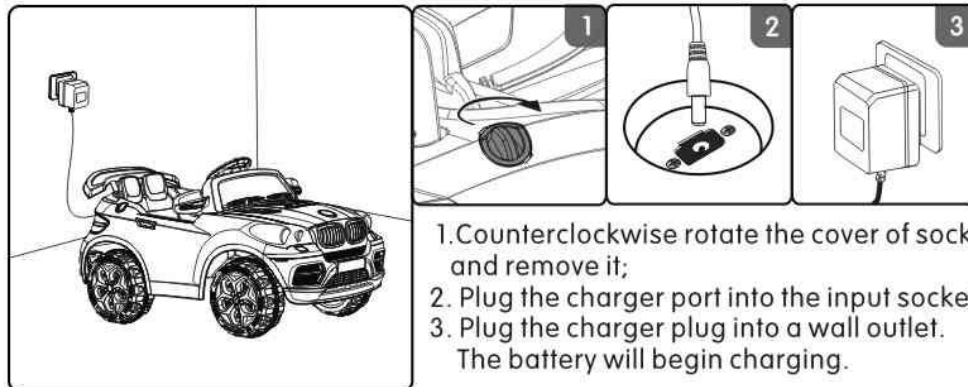

1. Counterclockwise rotate the cover of socket , and remove it;
2. Plug the charger port into the input socket;
3. Plug the charger plug into a wall outlet.
The battery will begin charging.

Caring For Your Vehicle

- Vehicle Body is molded by polypropylene. Solarize or in -15°C use are strictly prohibited. Vehicles should be far away from a hot objects, like an oven and heater, plastic parts may melt beside.
- Avoid operating the vehicle in wet or snowy conditions; and do not spray the vehicle with a hose. Do not wash the vehicle with soap and water. water or moisture in the motors or electrical switches can cause them to corrode and could cause switch or motor failure.
- Avoid operating the vehicle on sand, loose dirt or gravel. Sand , loose dirt or gravel in the motors or electrical switches can case them to jam , and could cause switch or motor failure.

- The vehicle can be wiped down with a soft ,dry cloth for a shiny finish, you can wipe plastic parts with a non–wax furniture polish applied to a soft–cloth . Do not use automotive wax, Do not use soap and water or spray the vehicle with a hose.
- Do not modify the electric system. When the fault appears and they must be maintained by professional. Alterations could cause a fire resulting in serious injury and could also ruin the electrical system.
- Use for about half month, check the wheels turning agilely or not, motor work is normal or not . infuse lube to lubricate moving parts.

Problems And Solutions Guide

The vehicle is equipped with a self–resetting fuse. When the vehicle is overloaded or operated incorrectly; the self–resetting fuse will be cut off for 5–20seconds before becoming operational again. The self–resetting fuse is under the seat (Refer to the picture.)

Bad status	checking points
vehicle moves slowly	check if the battery has been recharged long enough for 8~15 hours.
vehicle does not run	Check if the wires are correctly connected.
Battery can not recharge	check if the fuse is broken, if so replace it. check if the charger of the battery has been broken.

Circuit elements diagram

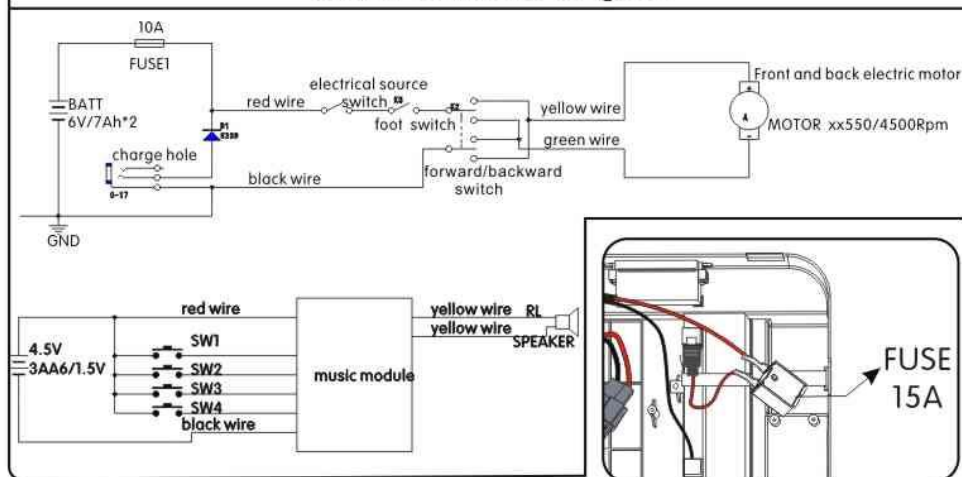



- Your sealed lead–acid battery must be recycled or disposed of in an environmentally sound manner.
- Do not dispose of your lead–acid battery in a fire. The battery may explode or leak.
- Do not dispose of a lead–acid battery in your regular, household trash. The incineration, land filling or mixing of sealed lead–acid batteries with household trash is prohibited bylaw.
- Return an exhausted battery to your local approved lead–acid battery recycle, such as local seller of automotive batteries.
- Contact your local waste management officials for other information regarding the environmentally sound recycling and disposal of lead–acid batteries.

 Adult operating required.

 requires two AA Batteries (not included) for operation .

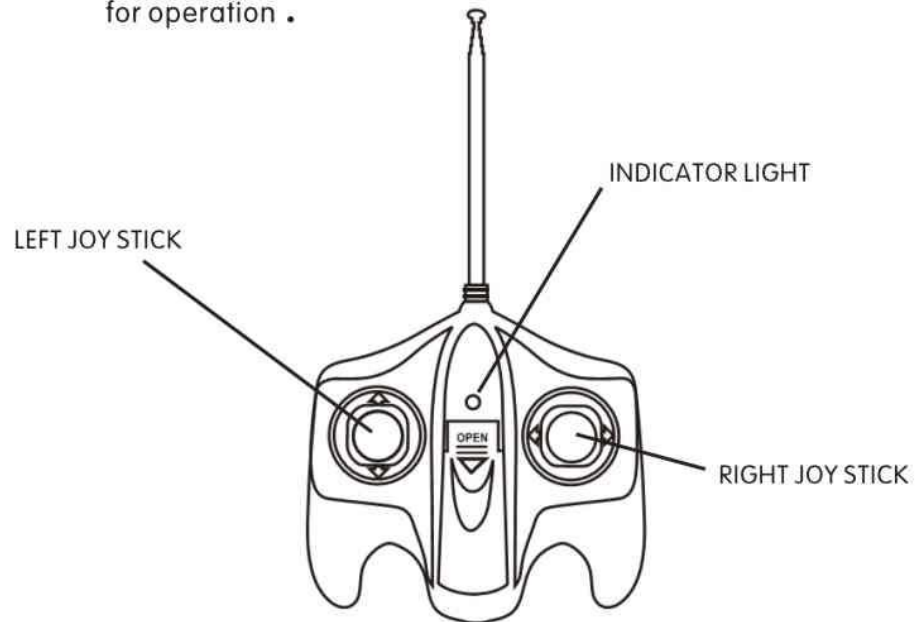

HOW TO USE THE REMOTE CONTROLLER

1. Push the LEFT JOY STICK to the front, the vehicle goes forward, pull the LEFT JOY STICK to the back, the vehicle goes backward.
2. Push the RIGHT JOY STICK to the left, the car turn left, push the RIGHT JOY STICK to the right, the vehicle turns right.

Our products are suitable for:

- **EN 71**
- **ASTM F 963**
- **EN62115**
- **GB6675**

The illustration adopted in the explanation is used for explaining product's operating measures and configuration. When there is little difference between assembly diagram and practicality, according to the real object please.

Improvement in vehicle will be added into the manual of new edition, There is no extra information. The company reserves the right to change the manual of its models at any time.